

Mosaic Panel Meters for Mosaic Panels (Indicator)



M4V Series PRODUCT MANUAL

For your safety, read and follow the considerations written in the instruction manual, other manuals and Autonics website.

The specifications, dimensions, etc. are subject to change without notice for product improvement. Some models may be discontinued without notice.

Features

- Various input options: 0 - 2 VDC $\bar{=}$, 0 - 10 VDC $\bar{=}$, 1 - 5 VDC $\bar{=}$, DC 0 - 1 mA, DC 4 - 20 mA
- High / low-limit display scale function
- Display range: -999 to 9999
- Display accuracy: F.S \pm 2 % rdg \pm 1-digit
- Error display function
- Built-in microprocessor

Safety Considerations

- Observe all 'Safety Considerations' for safe and proper operation to avoid hazards.
- \triangle symbol indicates caution due to special circumstances in which hazards may occur.

\triangle Warning Failure to follow instructions may result in serious injury or death.

- 01. Fail-safe device must be installed when using the unit with machinery that may cause serious injury or substantial economic loss. (e.g. nuclear power control, medical equipment, ships, vehicles, railways, aircraft, combustion apparatus, safety equipment, crime / disaster prevention devices, etc.)**
Failure to follow this instruction may result in personal injury, economic loss or fire.
- 02. Do not use the unit in the place where flammable / explosive / corrosive gas, high humidity, direct sunlight, radiant heat, vibration, impact or salinity may be present.**
Failure to follow this instruction may result in explosion or fire.
- 03. Install on a device panel to use.**
Failure to follow this instruction may result in fire.
- 04. Do not connect, repair, or inspect the unit while connected to a power source.**
Failure to follow this instruction may result in fire.
- 05. Check 'Connections' before wiring.**
Failure to follow this instruction may result in fire.
- 06. Do not disassemble or modify the unit.**
Failure to follow this instruction may result in fire.

\triangle Caution Failure to follow instructions may result in injury or product damage.

- 01. When connecting the power / measurement input and relay output, use AWG 24 (0.20 mm²) to AWG 15 (1.65 mm²) cable or over and tighten the terminal screw with a tightening torque of 0.98 to 1.18 N m.**
Failure to follow this instruction may result in fire or malfunction due to contact failure.
- 02. Use the unit within the rated specifications.**
Failure to follow this instruction may result in fire or product damage.
- 03. Use a dry cloth to clean the unit, and do not use water or organic solvent.**
Failure to follow this instruction may result in fire.
- 04. Keep the product away from metal chip, dust, and wire residue which flow into the unit.**
Failure to follow this instruction may result in fire or product damage.

Cautions during Use

- Follow instructions in 'Cautions during Use'.
Otherwise, It may cause unexpected accidents.
- Power supply should be insulated and limited voltage / current or Class 2, SELV power supply device.
- Install a power switch or circuit breaker in the easily accessible place for supplying or disconnecting the power.
- Keep away from high voltage lines or power lines to prevent inductive noise.
In case installing power line and input signal line closely, use line filter or varistor at power line and shielded wire at input signal line.
Do not use near the equipment which generates strong magnetic force or high frequency noise.

Connection with the line filter

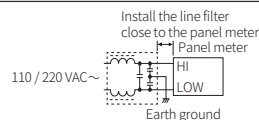

Connection with the varistor

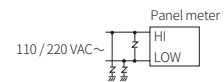

- This unit may be used in the following environments.
 - Indoors (in the environment condition rated in 'Specifications')
 - Altitude max. 2,000 m
 - Pollution degree 2
 - Installation category II

Product Components

- Product
- Instruction manual
- Bracket × 2

Dimensions

- Unit: mm, For the detailed drawings, follow the Autonics website.

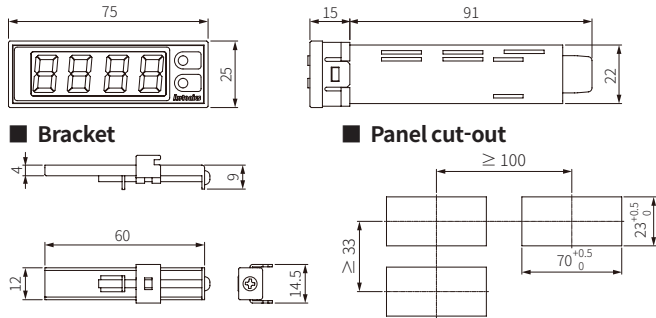

Cautions during Wiring

- Unit: mm, Use terminals of size specified below.

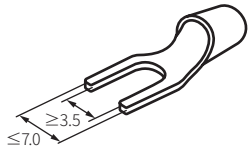

Connections

- Measurement input type: 0 - 2 VDC \approx , 1 - 5 VDC \approx , 0 - 10 VDC \approx

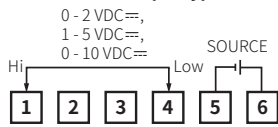

- Measurement input type: DC 0 - 1 mA

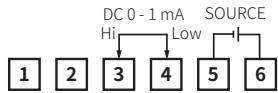

- Measurement input type: DC 4 - 20 mA

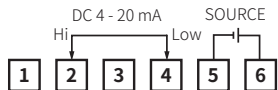

Specifications

| | |
|----------------------------------|--|
| Model | M4V |
| Input type | DC voltage, DC current |
| Measurement input type | 0 - 2 VDC \approx , 1 - 5 VDC \approx , 0 - 10 VDC \approx , DC 0 - 1 mA, DC 4 - 20 mA |
| Max. allowable input | \approx 110 % F.S. for each measured input range |
| Display method | 7-segment (red) LED (character height: 14 mm) |
| Display accuracy | Dependent on the ambient temperature |
| 0 to 50 °C | \pm 0.2 % F.S. rdg \pm 1-digit |
| -10 to 0 °C | \pm 0.3 % F.S. rdg \pm 1-digit |
| Display cycle | 0.5 sec |
| Unit weight | \approx 83 g |
| Certification | EMC |
| Power supply | 12 - 24 VDC \approx |
| Permissible voltage range | 90 to 110 % of rated voltage |
| Power consumption | \leq 2 W |
| Insulation resistance | \geq 100 M Ω (500 VDC \approx megger) |
| Dielectric strength | Between the charging part and the case: 2,000 VAC \sim 50 / 60 Hz for 1 min |
| Noise immunity | \pm 300 V square wave noise (pulse width: 1 μ s) by the noise simulator |
| Vibration | 0.75 mm double amplitude at frequency of 10 to 55 Hz in each X, Y, Z direction for 1 hours |
| Vibration (malfunction) | 0.5 mm double amplitude at frequency of 10 to 55 Hz in each X, Y, Z direction for 10 min |
| Shock | 300 m/s 2 (\approx 30 G) in each X, Y, Z direction for 3 times |
| Shock (malfunction) | 100 m/s 2 (\approx 10 G) in each X, Y, Z direction for 3 times |
| Ambient temperature | -10 to 50 °C, storage: -20 to 60 °C (no freezing or condensation) |
| Ambient humidity | 35 to 85 %RH, storage: 35 to 85 %RH (no freezing or condensation) |

Mode Setting

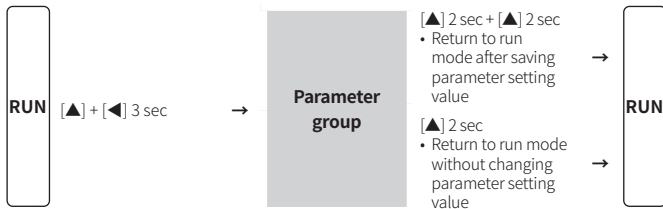

Parameter Setting

- If any key is not entered for 60 sec in each parameter, it returns to RUN mode.
- [◀] key: Changes setting digits.
- [▲] key: Changes setting values. / Save current parameter setting value and move to next parameter (When pressed for 2 sec)

Parameter group

| Parameter | Display | Defaults | Setting range |
|--|---------|----------|---|
| 1-1 Measurement input type | i n - t | 0 - 2 u | 0-2V, 1-5V, 0-10V, 1mA: DC 0 - 1 mA, 4-20: DC 4 - 20 mA |
| 1-2 Low-limit scale | L - 5 C | 0 0 0 0 | -999 to 9999 |
| 1-3 High-limit scale | H - 5 C | 0 0 | -999 to 9999 |
| 1-4 Decimal point position | d o t | 0 0 | 0.0, 0.00, 0.000, 0 |
| 1-5 Low-limit display value correction | i n - b | 0 0 0 0 | -99 to 99 |
| 1-6 Lock | L o c k | o f f | ON, OFF |

Error

Error display is released automatically when it is in the measured and display range.

| Display | Description | Troubleshooting |
|---------|---|--|
| HHHH | Flashes when measurement input is higher than the input range E.g.) Measurement input type = DC 4-20 mA, error display flashes when DC 22 mA or more is input. | Disconnect power supply and check the cables. |
| LLLL | Flashes when measurement input is lower than the input range E.g.) Measurement input type = DC 4-20 mA, error display flashes when DC 2 mA or less is input. | |
| o u E r | Flashes when the wiring is wrong or when an error occurs in the measurement input | Disconnect power supply and check the measurement input. |
| E r - E | Flashes when a memory chip that stores the setting values of the device is damaged, external noise, or malfunction of the power supply stage, etc. | Consult your Autonics sales representative. |

Connections of Applications

Simultaneous connection of voltmeter and ammeter

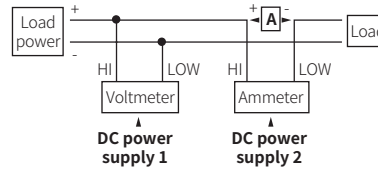

- As compared to measurement input range, higher measuring voltage needs a multiplier and lower measuring voltage needs a shunts.
- Connect the separated power supply each.
- (-) terminal of the power and (-) terminal of measurement input are shorted.
In case of using same power supply, measurement error or overcurrent may occur.

Scaling meter connection

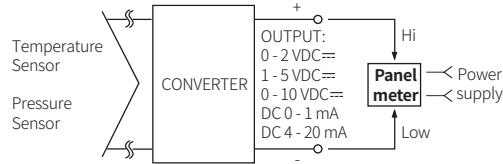

High / Low-limit scale value

This function is to display setting of particular high / low-limit value in order to display high / low-limit value of measured input.
If measured inputs are a and b and particular values are A and B, it will display a = A, b = B as below graphs.

- Set the high / low-limit scale values to be at least 1 or more different.

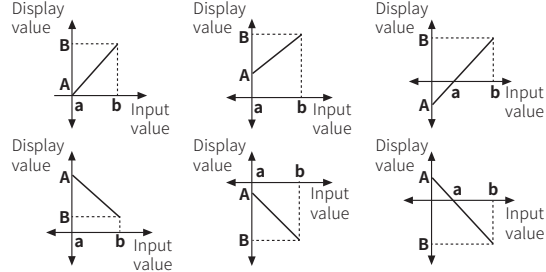

Segment Table

The segments displayed on the product indicate the following meanings. It may differ depending on the product.

| 7 segment | | | | 11 segment | | | | 12 segment | | | | 16 segment | | | |
|-----------|---|---|---|------------|---|---|---|------------|---|---|---|------------|---|---|---|
| 0 | 0 | l | l | 0 | 0 | l | l | 0 | 0 | l | l | 0 | 0 | l | l |
| 1 | 1 | u | J | 1 | 1 | u | J | 1 | 1 | u | J | 1 | 1 | u | J |
| 2 | 2 | e | K | 2 | 2 | e | K | 2 | 2 | e | K | 2 | 2 | e | K |
| 3 | 3 | L | L | 3 | 3 | L | L | 3 | 3 | L | L | 3 | 3 | L | L |
| 4 | 4 | n | M | 4 | 4 | n | M | 4 | 4 | n | M | 4 | 4 | n | M |
| 5 | 5 | n | N | 5 | 5 | n | N | 5 | 5 | n | N | 5 | 5 | n | N |
| 6 | 6 | o | O | 6 | 6 | o | O | 6 | 6 | o | O | 6 | 6 | o | O |
| 7 | 7 | P | P | 7 | 7 | P | P | 7 | 7 | P | P | 7 | 7 | P | P |
| 8 | 8 | q | Q | 8 | 8 | q | Q | 8 | 8 | q | Q | 8 | 8 | q | Q |
| 9 | 9 | r | R | 9 | 9 | r | R | 9 | 9 | r | R | 9 | 9 | r | R |
| A | A | S | S | A | A | S | S | A | A | S | S | A | A | S | S |
| b | B | t | T | b | B | t | T | b | B | t | T | b | B | t | T |
| C | C | u | U | C | C | u | U | C | C | u | U | C | C | u | U |
| d | D | v | V | d | D | v | V | d | D | v | V | d | D | v | V |
| E | E | w | W | E | E | w | W | E | E | w | W | E | E | w | W |
| F | F | x | X | F | F | x | X | F | F | x | X | F | F | x | X |
| G | G | y | Y | G | G | y | Y | G | G | y | Y | G | G | y | Y |
| H | H | z | Z | H | H | z | Z | H | H | z | Z | H | H | z | Z |